

OUT1 LED : Specifies the output OUT1.
OUT2 LED : Specifies the output OUT2.
HOUR LED : Selected time unit is HOUR.
MIN LED : Selected time unit is MINUTE.

- **SET** Timer value can be set in Running Mode , Parameter values can be set in Programming Mode and newly assigned parameter values can be saved . After parameter values are changed , new values are saved to memory and Running Mode is returned either by pressing **SET** button or by waiting 10 seconds.
- ▲ **▲** Timer is started by pressing **▲** button for 1 second , when *Strt* is selected (Except,either parameter or time set value changing) . Menu parameters can be accessed in Programming Mode. Parameter set values can be increased. Timer set value can be increased in Time Config Mode. Timer set value increases gradually accelerated by pressing continuously.
- ▼ **▼** Timer and audible warning are stopped by pressing **▼** button for 1 second. when *Strt* is selected (Except,either parameter or time set value changing) . Menu parameters can be accessed in Programming mode. Parameter set values can be decreased. Timer set value can be decreased in Time Config Mode. Timer set value decreases gradually accelerated by pressing continuously.

TIME CONFIG MODE



Running Mode switches to Time Config Mode by pressing **SET** button. Display indicates configuration mode is opened by flashing. Desired timer set value can be set by pressing **▼▲** buttons. After desired timer value set, new timer set value is saved to memory and Running Mode is returned either by pressing **SET** button or by waiting 10 seconds.

Programing Menu is opened and *Conf* parameter is seen by pressing **SET** and **▲** buttons at same time. Switching between menu parameters is done by pressing **SET** button. While one of menu parameter is seen, sub-menu parameter is opened when pressing **▼** button.

In order to change sub-menu parameters value, press **▼▲** buttons while holding **SET** button down. When **SET** button is released , all changes will be saved to memory and related sub-menu parameter is returned. Programming Menu is returned from sub-menu parameters by pressing **▼▲** buttons at same time. In the sub-menu , all changes will be saved to memory and Running Mode is returned from sub-menu if no key is pressed for 10 seconds. In programming menu , all changes can be saved to memory and Running Mode can be returned from programming menu either by pressing **SET** and **▲** buttons at same time or if no key is pressed for 10 seconds.

Programming Menu

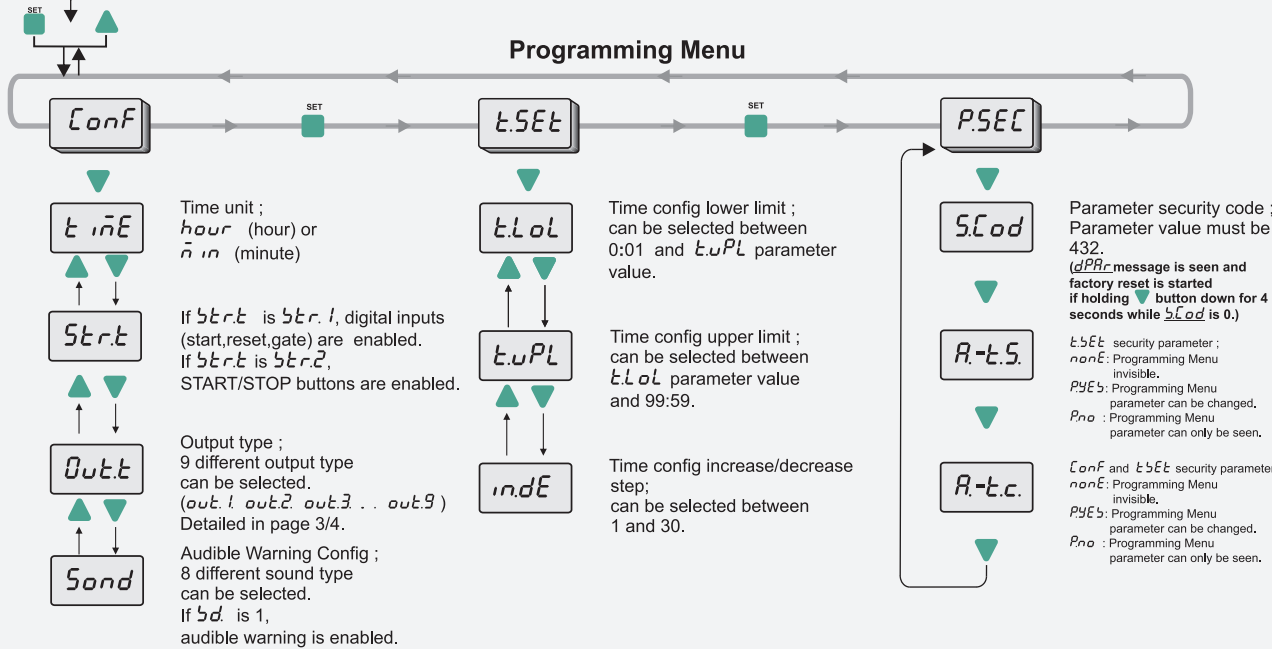

Parameter Configuration Diagram



In order to set related parameter to desired value , hold **SET** button down, when display is started to flash use **▲▼** buttons. Value increases/decreases gradually accelerated by pressing **▲▼** buttons continuously.

NOTE : Selected area indicates the moment of power-up, if the external "START" input is active.

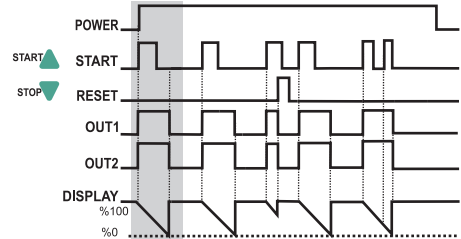
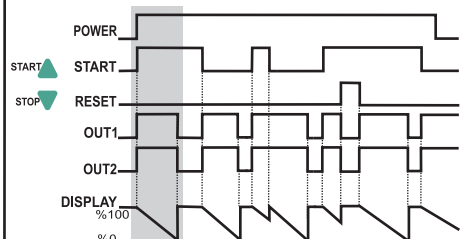
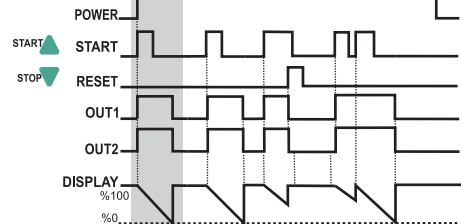
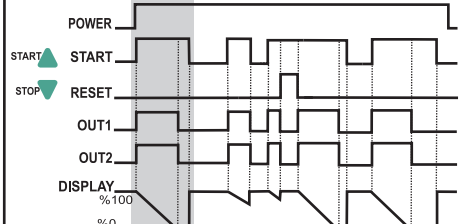
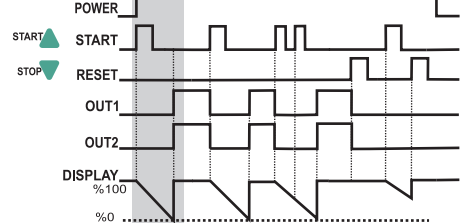
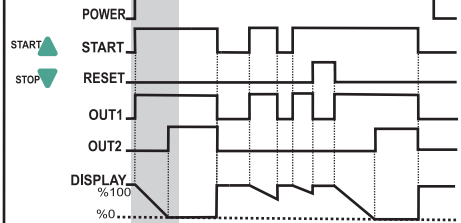
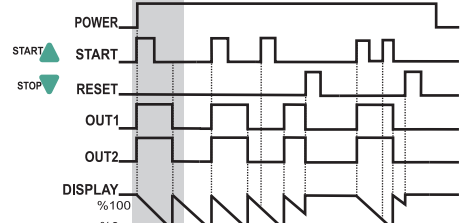
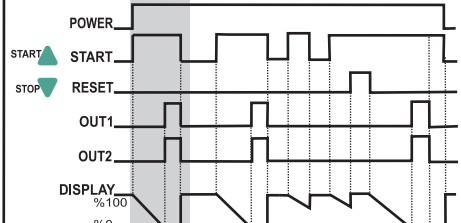
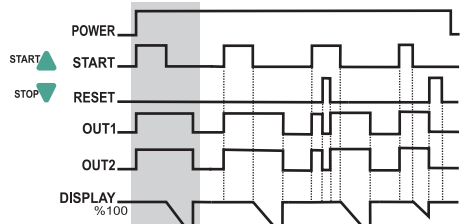
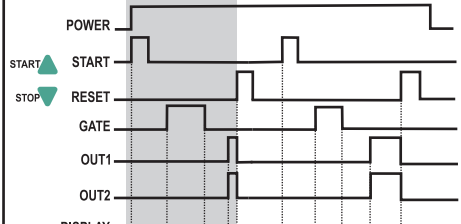
<p>Out.1</p>  <p>When device is powered, If START input is set OUT1 and OUT2 relays are turned on. When timer set value is expired , OUT1 and OUT2 relays are turned off. If RESET input is set before timer set value expires OUT1 and OUT2 relays are turned off and timer set value is renewed.</p>	<p>Out.6</p>  <p>When device is powered, If START input is set OUT1 and OUT2 relays are turned on and timer starts counting down. If START input is reset , timer value is renewed to timer set value and timer starts counting down. If START input is set again , timer value is renewed to timer set value. When timer set value is expired, OUT1 and OUT2 relays are turned off and timer value is renewed to timer set value. If RESET input is set, OUT1 and OUT2 relays are turned off and timer value is renewed to timer set value.</p>
<p>Out.2</p>  <p>When device is powered, If START input is set OUT1 and OUT2 relays are turned on. When timer set value is expired, OUT1 and OUT2 relays are turned off. If RESET input is set before timer set value is expired OUT1 and OUT2 relays are turned off and timer set value is renewed. If START input is set before timer set value is expired , relays remain turned-on and timer set value is renewed and timer starts counting down.</p>	<p>Out.7</p>  <p>When device is powered, If START input is set OUT1 and OUT2 relays are turned on and timer starts counting down from timer set value .When timer set value is expired, OUT1 and OUT2 relays are turned off. If START input is reset after an timer set value is expired, timer value is renewed to timer set value. If START input is reset while timer counts down , OUT1 and OUT2 relays are turned off. If RESET input is set while START input is set , OUT1 and OUT2 relays are turned off and timer value is renewed to timer set value. If RESET input is reset while START input is set , OUT1 and OUT2 relays are turned on and timer starts counting down</p>
<p>Out.3</p>  <p>When device is powered , If START input is set timer starts counting down. When timer set value is expired, OUT1 and OUT2 relays are turned on and timer set value is renewed. If START input is set again, OUT1 and OUT2 relays are turned off and timer starts counting down. If RESET input is set OUT1 and OUT2 relays are turned off and timer stops counting down.</p>	<p>Out.8</p>  <p>When device is powered, If START input is set OUT1 relay is turned on and timer starts counting down from timer set value. When timer set value is expired, OUT2 relay is turned on. If START input is reset when timer set value is expired, timer value is renewed to timer set value . If START input is reset while timer counts down OUT1 and OUT2 relays are turned off. If RESET input is set while START input is set , OUT1 and OUT2 relays are turned off and timer value is renewed to timer set value. If RESET input is reset while START input is set , OUT1 relay is turned on and timer starts counting down.</p>
<p>Out.4</p>  <p>When device is powered, If START input is set OUT1 and OUT2 relays are turned on. When timer set value is expired, OUT1 and OUT2 relays are turned off , timer set value is renewed and timer starts counting down again. This process periodically continues. If RESET input is set OUT1 and OUT2 relays are turned off and timer stops counting down.</p>	<p>Out.9</p>  <p>When device is powered, If START input is set , timer starts counting down. When timer set value is expired, OUT1 and OUT2 relays are turned on. If START input reset when timer set value is expired, OUT1 and OUT2 relays are turned off and timer value is renewed to timer set value. If START input is reset while timer counts down , timer value is renewed to timer set value. If RESET input is set while START input is set , timer value is renewed to timer set value. If RESET input is reset while START input is set , timer value is renewed to timer set value. and starts counting down.</p>
<p>Out.5</p>  <p>When device is powered, If START input is set OUT1 and OUT2 relays are turned on. When START input is reset timer starts counting down. When timer set value is expired, OUT1 and OUT2 relays are turned off and timer set value is renewed. If START input is set while timer counts down, timer set value is renewed. When START input is reset timer starts counting down. If RESET input is set OUT1 and OUT2 relays are turned off and timer stops counting down.</p>	<p>GATE USAGE</p>  <p>When device is powered, If GATE input is set ,timer set value is seen on display and timer stops counting down. If GATE input is reset , timer continue where it remains. If RESET input is set while GATE input is reset, OUT1 and OUT2 relays are turned off and timer value is renewed to timer set value.</p>

CAL ETM2432 DIGITAL TIMER PARAMETERS

CONFIGURATION PARAMETERS

Parameter Name	Functional Specification	Min.	Max.	Unit	Factory Settings
<i>t_{inE}</i>	Device time config	00:01	99:59	hr:min min:sec	<i>n in</i>
<i>St_rt</i>	Device input control parameter	<i>St_r.1</i>	<i>St_r.2</i>		<i>St_r.1</i>
<i>Out_t</i>	Device output control parameter	<i>Out.1</i>	<i>Out.9</i>		<i>Out.1</i>
<i>S_ond</i>	Device audible warning control parameter	<i>Sd.1</i>	<i>Sd.8</i>		<i>Sd.1</i>

TIMER CONFIGURATION PARAMETERS

<i>t_LoL</i>	Time config lower limit define parameter	00:01	99:59		00:01
<i>t_UP_L</i>	Time config upper limit define parameter	00:02	99:59		99:59
<i>i_ndE</i>	Time config increase/decrease coefficient parameter				

SECURITY PARAMETERS

<i>SCod</i>	Security code parameter	0	9999		0
<i>R-t.S</i>	Time config security parameter				YES
<i>R-t.c</i>	Menu security parameter				YES

Note 1: If *St_rt* selected *St_r.1*, Control is provided with START - RESET - GATE inputs.

Note 2: If *St_rt* selected *St_r.2*, Control is provided with device front panel START (▲) - STOP (▼) buttons.

Note 3: GATE input can be used for all *St_rt* and *Out_t* types.

Note 4: When *St_rt* parameter switched from *St_r.1* to *St_r.2*, device continue to work with present *Out_t* output setting. Timer can be stopped with device front panel STOP (▼) button in case of need.

Note 5: Cases in **Note 4** also valid for *St_rt* parameter switched from *St_r.2* to *St_r.1*, digital RESET input can be used instead of STOP button.

Note 6: In Running Mode, if the , ▲ and ▼ keys are pressed together, revision number appears on display. (In order to show the revision number, *St_rt* parameter must be set to *St_r.1* in *CONF* menu).