



KS vario

Modular controller system

Highly modular system with 4 to 30 loops:
bus coupler, controller unit, any I/O modules

Required components are simply plugged together:
the interconnections are made automatically

Open for all interfaces: Ethernet IP, Ethernet Mod/TCP,
Profibus DP, CANopen, DeviceNet, Modbus

Digital and analog I/O modules in different
modularities: 2, 4, 6, 8 or 16 channels

Separate RS232-interface for
BlueControl Engineering Tool

Latest control technology with complete functional
range for the most varied applications

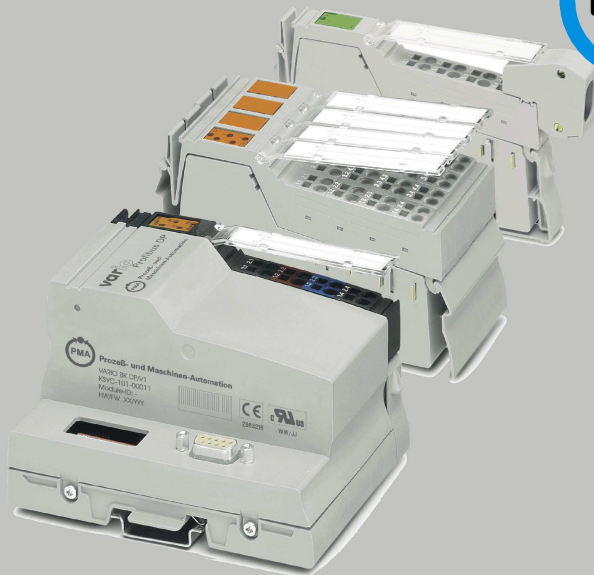

- Construction of de-central controller systems with any external I/Os at a max. distance of 400 m via remote bus
- Scanning rate adjustable per channel: from 100 ms
- Free wiring of all inputs & outputs
- Additional usage as I/O-system: up to 34/60 analog I/Os and 320 digital I/Os
- 2 automatic self-tuning procedures
- Controlled start-up
- Automatic start-up and boost functions
- Switch-over to output 'hold' on sensor break
- Heating current monitor and alarm for input & control loops
- Automatic heating current limit setting via trigger signal
- Compensation of mains voltage variations during heating current measurement – separate for each phase
- Transmitter functionality
- Direct connection of pressure sensors
- On-line calibration
- E-tool with system configurator and operation/visualization of the system
- Software update in Flash EPROM via the Engineering Tool

- Comfortable access via any fieldbus terminal module with free configurable process data cache

APPLICATIONS

- Plastics processing
- Melt pressure control
- Hot runners
- Mold heating
- Textile machines
- Packaging machines
- Semiconductor production
- Industrial Furnaces
- Driers
- Climatic chambers
- Heat treatment
- Burner & boiler control
- Medical technology
- Sterilizers

DESCRIPTION

The **KS vario** is the central component of the modular **vario** multi-controller system, and is suitable for precise cost-effective control tasks in all industrial areas. For this, it is possible to choose between simple on/off control, DPID control, motorized stepping or master/slave control for each channel. Due to the modular system concept, any combination of input & output signals can be implemented. By means of the integrated monitoring functions for heating current and input/control loops, every fault in the entire control loop can be diagnosed.

Modular, up to 30 channels

As standard, the **KS vario** is fitted with the necessary I/O for up to 8 control loops. Simply by plugging additional I/O modules into the system, a finely graduated expansion up to 30 control loops is possible.

This means that no more I/O modules have to be installed than actually needed. The maximum configuration allows up to 60 analog outputs, up to 34 analog inputs and up to 320 digital inputs or outputs to be processed.

Every system is connected to an arbitrary field bus coupler, which also provides the supply voltage for the entire system.

Thus only **one** field bus coupler, **one** **KS vario** controller, and possibly some additional I/O modules are required per multi-controller system.

Automatic inter-connections reduce installation time

The necessary modules of a **vario** system are simply plugged together without the need for tools. All peripheral and data signals, as well as the supply voltages are connected automatically. The external 24 VDC system supply must only be connected to the bus coupler at one point.

Thanks to the plug-in spring clamp connectors for the I/O wiring, quick and simple module replacement is ensured. Identifying labels provide convenient I/O marking.



Engineering Tool "BlueControl"

Configuration of the **KS vario** is done by means of the powerful and easy-to-use Engineering Tool "BlueControl", which is connected via a separate RS 232 interface on the **KS vario**. Furthermore, BlueControl also allows convenient operation and monitoring of the control system, plus simulation functions for control mode and control loop.

Fast software update via BlueFlasher

Via the local RS 232 interface of the **KS vario**, loading a software update into the controller's Flash EPROM is a simple matter.

Simple system configuration via BlueControl

Apart from a field bus coupler and a **KS vario** controller, there is choice of some 20 different I/O modules for making up a **KS vario** multi-controller system. Hereby, the number of required control loops (max. 30) is just as freely selectable as the signal types for inputs/outputs.

Of course, the system's configuration can also be done via the field bus.

The following I/O modularities are available:

Digital I/O: 2, 4, 8 and 16 channels

Analog I/O: 2, 4, and 8 channels

The **KS vario** automatically tests whether the system configuration assigned via BlueControl or field bus confirms with the modules actually connected.

See below for a list of available modules.

Construction of de-central controller systems

Any number of external input and outputs can be connected via a remote bus using bus branch modules. Any branching by means of several remote bus lines is possible. Max. overall length per remote bus: 400 m.

Application:

Remote temperature measurement near the heatings. Outputs and controller system installed in the control cabinet.

Flexible scanning rates from 100 ms

The **KS vario** system offers free scaling of the control loops with a fixed time scale. This allows high flexibility when adapting to the connected control loops. For example, the combination of fast mold heating with slow barrel heating presents no problems. The minimum adjustable scan rate is 100 ms. Thus 6 control loops can be measured and computed within 200 ms.

Furthermore, BlueControl provides a very convenient means for adjusting the scan rate of every channel individually.

Input circuit monitoring and output 'hold' on sensor break

In case of a fault in a measurement circuit, the built-in monitoring function ensures increased operational safety for the plant. The inputs are monitored for break, short circuit, and wrong polarity of sensor and leads.

If the monitor is triggered, the controller's output action can be defined as follows:

- Predefined output value
- Outputs disabled
- 'Hold' of mean output value

In order to continue with production in case of a sensor break, it is necessary to maintain the temperature at the last mean value of the output signal.

The **KS vario** signals a sensor break via the field bus or an alarm output, so that the sensor can be replaced. As soon as the **KS vario** detects a valid input value after replacement, controller operation is continued automatically.

Control loop monitoring (loop alarm)

The control loop monitoring function checks the functionality of the entire control loop. It detects if there is no change of the process value after a corresponding change of the output signal

Measurement value correction

The correcting function is used to change or scale the measurement value. Especially convenient is the option for implementing the changes online via a screen display of the "BlueControl" Engineering Tool.

Alarm and safety functions, alarm outputs

The **KS vario** offers comprehensive alarm processing functions. Arbitrary alarm signals can be assigned to max. 6 digital outputs.

If several alarm signals are assigned to one output, the internal connections are made automatically.

The following alarm signals are available per channel:

- Relative measured value alarm for monitoring the control deviation (process value – setpoint)
- Absolute measured value alarm for monitoring limit values, independent of setpoint value.
- Relative measured value alarm with alarm suppression, i.e. the alarm is not triggered during start-up or setpoint changes.
- Loop alarm (control loop monitoring)

- Sensor fault alarm
- Heating current alarm

Heating current monitoring and alarm

One current transformer per max. 8 heating zones can be connected to the **vario** system. Rectification of the transformer signal is done by the **KS vario** controller or by the **vario** I/O modules with heating current input.

Apart from measuring all the heating currents, every value is monitored for a minimum limit and for short circuit of the solid-state relay. If a limit is exceeded, this information is used to trigger a digital output or it is transferred to the field bus with an indication of the respective channel number.

Automatic heating current limit setting via trigger signal

Alternatively to the individual setting of each heating current limit value, the limit values of all monitored zones can be set automatically by means of a "heating current trigger signal" (also directly via the BlueControl tool operating page). In this case, the heating current limit values are formed from the actual measured values minus a heating current tolerance: HC.tol. This parameter indicates the max. permissible deviation from the "normal" heating current process value in per cent (0...50).

Variations of the mains voltage are compensated during heating current measurement

To prevent variations in the mains voltage from affecting the computation of the heating current monitor, the **KS vario** system is able to measure mains voltage (1 phase or all 3 phases separately). The measured mains supply values are compensated according to the adjustable reference value in the controller.

Controller & positioner operation

The **KS vario** is configurable as a signaller, two or three-point controller, three-point controller with evaporative water cooling, master/slave operation, or for three-point stepping control. Similarly, it can be configured for continuous or split-range control. Furthermore, bumpless auto/manual switchover is provided. During manual operation, the positioning output can be set to any value or relative duty cycle.

Melt pressure measurement for extrusion plants

The **KS vario** system has inputs for the direct connection of melt pressure sensors.

Second setpoint and ramp function

Via any of the digital inputs or the field bus, a second setpoint can be activated (e.g. for setpoint lowering).

By means of the setpoint gradient (ramp) function, which starts automatically during system start-up and after every change of the setpoint value, the function ramps up or down to the new setpoint value.

Ramped heat-up

This 'automatic' temperature ramping function prevents thermal stresses within a group of heating zones. The **KS vario** automatically detects the zone with the slowest heating gradient, and controls the gradient of all the other zones accordingly, until the set points are reached. This happens independently of actual process values, i.e. zones that might already be warm are not heated until the other zones have reached the same value, after which they are heated together up to their respective setpoints.

Start-up circuit

High-performance heating elements with magnesium oxide insulation must be heated slowly, to remove any humidity and to prevent destruction.

With activated start-up circuit, the controller uses the adjusted start-up temperature (e.g. 40%) until reaching the start-up setpoint (e.g. 95°C). For protection of the heating elements, the duty cycle is reduced to ¼ during start-up.

The start-up setpoint (e.g. 95°C) is maintained during the selected start-up holding time. Subsequently, the controller uses the main setpoint W.

Boost function

The boost function briefly switches all the control loops to a higher setpoint, e.g. to remove scale from the nozzles during mold heat-up.

Self-tuning

This function is fitted as standard for automatic determination of the best control parameters. Self-tuning is started on demand via the field bus or the Engineering Tool, and uses the delay time T_u and the max. rate of change V_{max} of the temperature control loop to calculate the optimum settings for fast line-out without overshoot.

With three-point controller configuration, the "cooling" parameters are determined separately. Self-tuning also works with an activated start-up function. For applications with adjacent heating zones and strong thermal coupling, synchronous self-tuning can be started for the loops involved (max. 30). Synchronous self-tuning can be activated or disabled individually for every control loop. Up to 4 different groups can be synchronized with this procedure.

Self-tuning at setpoint

This newly developed feature determines the optimum control parameters also at setpoint, either on request or automatically (following a detected tendency to hunt). The procedure works without oscillation, and with only a minimum variation of the controlled variable.

Control functions via digital inputs

Up to 8 digital inputs can be assigned for the following remote control functions for any of the control channels:

- Switch-over to a different set of parameters
- Disabling of all controllers
- Switch-over to 2nd setpoint
- Boost function for hot runners
- Auto/manual switch-over
- Data read-out via field bus

Signal assignment to digital outputs

Max. 60 digital outputs can be assigned to the following signals:

- Heating or cooling signal
- Any common alarm
- Remote control via field bus

Signal assignment to analog outputs

Max. 60 analog outputs can be assigned to the following signals:

- Control signal (heating and cooling)
- Control signal (only heating)
- Control signal (only cooling)
- Process value (transmitter function)
- Setpoint
- Remote control via field bus

Forcing

All unused digital and analog outputs can be 'forced' via the field bus. Similarly, all inputs can be read via the field bus.

Watchdog

The **KS vario** is fitted with a hardware watchdog, that is triggered internally every 0,26 seconds.

TECHNICAL DATA KS vario

For data of the other system modules, please refer to the relevant data sheets. A survey of the modules is given below.

VERSIONS OF KS vario

4 different versions of controllers:

KS VARIO T4/UTH

- 4 Thermocouple inputs
- 1 heating current input
- 8 digital outputs
- max. 4 control loops

KS VARIO T8/UTH:

- 8 Thermocouple inputs
- 1 heating current input
- 8 digital outputs
- max. 30 control loops

KS VARIO T4/RTD

- 4 Resistance inputs
- 1 heating current input
- 6 digital outputs
- max. 4 control loops

KS VARIO T6/RTD

- 6 Resistance inputs
- 1 heating current input
- 6 digital outputs
- max. 30 control loops

INPUTS

Version KS vario Tx/UTH

Thermocouples

Types L, J, K, N, S, and R to DIN IEC584

Type	Meas. range	Error
B	400...1820 °C	≤ 3 K
C	0...2315 °C	≤ 3 K
D	0...2315 °C	≤ 3 K
E	-100...1000 °C	≤ 3 K
J	-100...1200 °C	≤ 2 K
K	-100...1350 °C	≤ 2 K
L	-100... 900 °C	≤ 2 K
N	-100...1300 °C	≤ 2 K
R	0...1760 °C	≤ 3 K
S	0...1760 °C	≤ 3 K
T	-200...400 °C	≤ 2 K

Display: in °C or °F
 Resolution of A/D converter: >14 bits
 Input resistance: ≥1 MΩ
 TC break monitor:
 with configurable output action
 Monitoring current: ≤ 1 μA

Polarity monitoring:
 responds when input signal is 30 K below span start.
 Temperature compensation: built in

Sensor or compensating lead must be taken up to the controller terminals.

Additional error: $\leq 1 \text{ K}/10 \text{ K}$ change of terminal temperature

Permissible voltages between inputs: 1 VDC and 2 VAC

Permissible voltage between inputs and ground: 5 VAC

Direct voltage

Range: 0...70 mV linear
Input resistance: $\geq 1 \text{ M}\Omega$
Error: $\leq 0,1 \%$
Input span scalable via measurement correction.

Version KS vario Tx/RTD

Resistance thermometer

Pt 100 to DIN IEC 751

Range: -200,0...850,0 °C
With linearization (temperature-linear)
Display error: $\leq 1 \text{ K} \pm 1 \text{ digit}$
Resolution of A/D converter: $>14 \text{ bits}$

Connection in three-wire technique without lead adjustment.
With two-wire connection, a calibrating resistor equal to the lead resistance must be fitted.

Lead resistance: $\leq 30 \Omega$
Sensor current: $\leq 0,3 \text{ mA}$
Input circuit monitoring for break in sensor or lead, or short circuit.

Configurable output action.

Resistive input, linear

Range: 0...450 Ω , without linearization
Connection in three-wire technique without lead adjustment.
With two-wire connection, a calibrating resistor must be fitted.
Sensor current: $\leq 0,3 \text{ mA}$

Input circuit monitoring for break in sensor or lead.

Scanning rate

scalable from 100 ms
Rate per 4 channels: $>100 \text{ ms}$

Heating current input, heating current monitor

Current summing principle (1 current transformer for max. 8 heaters).
Connection of conventional current transformers.
Input span: 0...50 mA AC
Input resistance: approx. 170 Ω

e.g. for PMA standard current transformer 0...50A / 0...50 mA AC

Short circuit of the solid-state relay

Threshold value of the short-circuit monitor: 1,5 % of selected span

(e.g. 0,45 A with a span of 30,0 A)

Compensation of mains voltage variations during heating current measurement

Separate for every phase

The mains voltage is measured via a converter module (accessory) and must be connected to an analog input module (e.g. VARIO AI 2/SF)

CONFIGURATION INTERFACE OR PANEL INTERFACE

Connection for PC / BlueControl Tool or panel for local operation: KSvarioBT

Type: V.24 / RS 232
address and baudrate adjustable
Max. cable length: 3 m

Local bus for vario I/O modules

via data routing

Local bus for KS vario bus coupler

via data routing

OUTPUTS

Logic outputs

Depending on version (RTD or UTH), 6 or 8 outputs are available for connecting solid-state relays or as alarm outputs.

Outputs are short-circuit proof, and switch 24 VDC (grounded load).
Nominal range of switched output voltage: 18...30 VDC to DIN 19 240.

Nominal output current: 70 mA

Voltage drop across output at full load: 0,6 V typical, 1 V max.

POWER SUPPLY

Analog supply: 24 V $\leq 30 \text{ mA}$
Logic supply: 7,5 V $\leq 150 \text{ mA}$
via potential routing

Segment supply: 24 V DC $\leq 500 \text{ mA}$
via potential routing

Protection class III (protective low voltage).

CONTROL CHARACTERISTICS

Configurable as:

- Signaller with 1 or 2 outputs
- Two-point DPID controller
- Three-point DPID/DPID controller
- Three-point DPID/DPID controller with output algorithm for evaporative water cooling (extruders)

- Split-range controller
- Continuous controller
- Positioner function with manual operation of three-point controller
- Three-point stepping controller
- Master/slave controller
- Control parameters
- Self-tuning function or adjustable parameters
- Start-up function
- Automatic ramping / controlled heat-up
- Boost function

ALARM FUNCTIONS

Output: logic signal or via interface
The following alarms are configurable for every control loop:

- relative or absolute measured value alarm
- relative measured value alarm with alarm suppression
- Sensor break alarm
- Heating current alarm
- Control loop alarm

STATUS DISPLAYS

Display LEDs for:

- Bus diagnostics
- Run
- Self-tuning
- Alarm
- Error message

PROGRAM MEMORY

Flash EPROM
Firmware update via BlueControl Tool

ENVIRONMENTAL CONDITIONS

Permissible Temperatures

Ambient temperature (operation): 0...55 °C
Ambient temperature (storage/transport): -25...85 °C

Humidity

Humidity (operation): 75 % on average; 85 % occasionally; no condensation

Humidity (storage/transport) 75%, on average; 85%, occasionally. no condensation

INFLUENCING FACTORS

Power supply effect

None. In case of mains failure, the configuration data are stored in a non-volatile EEPROM.

Vibration test

sinusoidal vibrations according to IEC 60068-2-6; EN 60068-2-6
5g load, 2 hours for each space direction

Shock test

according to IEC 60068-2-27; EN 60068-2-27
25g load for 11 ms, half sinusoidal wave, three shocks in each space direction and orientation

ELECTROMAGNETIC COMPATIBILITY

Noise Immunity Test according to EN 50082-2

Electrostatic discharge (ESD) according to EN 61000-4-2 / IEC 61000-4-2

- Criterion B
- 6 kV contact discharge
- 8 kV air discharge

Electromagnetic fields according to EN 61000-4-3, IEC 61000-4-3

- Criterion B
- Influencing factor max. 1% of the range in the frequency-range of 400-1000MHz (only RTD-versions)
- Field strength: 10 V/m

Fast transients (burst) according to EN 61000-4-4 / IEC 61000-4-4

- Criterion B
- Remote bus: 2 kV
- Voltage supply 2 kV
- I/O cables: 2 kV
- Criterion A
- All interfaces: 1 kV

Surge voltage according to EN 61000-4-5/ IEC 61000-4-5

- Criterion B
- AC supply lines: 2.0 kV/4.0 kV (symmetrical/asymmetrical)
- DC supply lines: 0.5 kV/0.5 kV (symmetrical/asymmetrical)
- Signal lines: 1.0 kV/2.0 kV (symmetrical/asymmetrical)

Conducted interference according to EN 61000-4-6, IEC 61000-4-6

- Criterion A
- Test voltage 10 V

Noise Emission Test According to EN 50081-2

Noise emission of housing:
EN 55011 Class A

GENERAL

Housing

Dimensions (W x L x H):
48,8 x 71,5 x 120 mm

(needed space in case of using RS232 connector: 35mm)

Drawing: *KS vario T8/UTH*

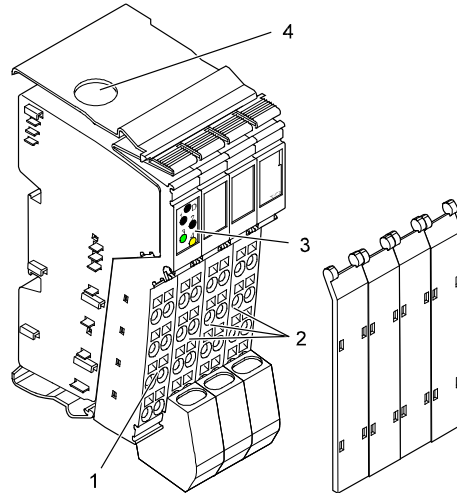

- 1 Outputs
- 2 Inputs
- 3 Diagnostic- and status-display
- 4 RS232-interface

Protection mode

IP 20

Protection class

Class 3 to IEC 60 536 (VDE 0106)

CE marking

Fulfills the European Directives for electromagnetic compatibility and low voltage.

Certificates

UL listing, CSA certification

Electrical connections

Screwless spring-clamp connector strips

Mounting method

Clip-on rail mounting ('top-hat' rails to DIN EN 50 022)

Weight

Approx. 122 g (without connector strips)

Housing material

Basic material: Crastin PA6.6, self-extinguishing (V0)

Accessories supplied

- Connector strips
- Label for inscriptions
- Mounting instructions

SUPPLEMENTARY EQUIPMENT

BlueControl (Engineering Tool)

PC-based program for configuration, parameter setting, and operation (commissioning) of the **KS vario** system. All settings are stored, and can be printed on request. Moreover, a powerful data acquisition module with trend graphics is available.

Simulation

The built-in simulation serves to test the controller settings, but can also be used for general training and observing the interaction between controller and process.

Online measurement value correction

Calibration of the entire input circuit is possible with just a few mouse clicks.

System configurator

Choice of **KS vario** bus coupler and I/O modules.

Software requirements

Windows 9X/NT/2000/XP

Hardware requirements

An RS 232 cable (Sub-D connector) is required for connecting to the **KS vario** system (Accessories).

Updates and demonstration software from:

www.pma-online.de

Functionality	BlueControl-Engineering-Tool	Mini	Standard	Expert
Setting of parameters and configurations	yes	yes	yes	yes
Controller & control loop simulation	yes	yes	yes	yes
Download: transfer of an Engineering to the controller	yes	yes	yes	yes
Online mode / Visualization	only SIM	yes	yes	yes
Upload: read-out of an Engineering from the controller	only SIM	yes	yes	yes
File, save Engineering	no	yes	yes	yes
Print function	no	yes	yes	yes
Online documentation / Help	yes	yes	yes	yes
Implementation of measured value correction	no	yes	yes	yes
Data acquisition and trend recording	only SIM	yes	yes	yes
System configurator	yes	yes	yes	yes
Enhanced simulation functionality (laplace...)	no	no	no	yes

MODUL OVERVIEW: Modular Closed Loop Control System KS vario

Notation	Order-no.	Function
Fieldbus Coupler		
KS VARIO BK DP/V1	KSVC-101-00111	Profibus bus terminal module, Standard-Profibus-DP and extension DP/V1, 24 V DC, spring-clamp connection, labeling field
KS VARIO BK CAN	KSVC-101-00121	CANopen bus terminal module, 24 V DC, spring-clamp connection, labeling field
KS VARIO BK ETH	KSVC-101-00131	ETHERNET Mod/TCP bus terminal module, 24 V DC, spring-clamp connection, labeling field
KS VARIO BK IP	KSVC-101-00181	ETHERNET IP bus terminal module, 24 V DC, spring-clamp connection, labeling field
KS VARIO BK DN	KSVC-101-00141	DeviceNet bus terminal module, 24 V DC, spring-clamp connection, labeling field
KS VARIO BK MOD	KSVC-101-00151	Modbus bus terminal module, 24 V DC, spring-clamp connection, labeling field
Bus Coupler for Remote I/O		
VARIO RM TX	KSVC-101-00211	Vario bus branch module for remote bus, spring-clamp connection, labeling field
VARIO RM BK	KSVC-101-00201	Vario bus receiver module for remote I/Os, 24 V DC, spring-clamp connection, labeling field
Closed Loop Controller		
KS VARIO T4/RTD	KSVC-104-x0331	Vario temperature controller, 4-channel, spring-clamp connection, labeling field, 4 inputs, RTD (resistance element), 3 wire connection + screening, 6 outputs 24 V DC, 1 heating current input, I/O extensible
KS VARIO T4/UTH	KSVC-104-x0431	Vario temperature controller, 4-channel, spring-clamp connection, labeling field, 4 inputs, TC (thermocouples), 2 wire connection + screening, 8 outputs 24 V DC, 1 heating current input, I/O extensible
KS VARIO T6/RTD	KSVC-104-x0341	Vario temperature controller, up to 30-channel, spring-clamp connection, labeling field, 6 inputs, RTD (resistance element), 3 wire connection + screening, 6 outputs 24 V DC, 1 heating current input, I/O extensible up to 30 channels
KS VARIO T8/UTH	KSVC-104-x0441	Vario temperature controller, up to 30-channel, spring-clamp connection, labeling field, 8 inputs, TC (thermocouples), 2 wire connection + screening, 8 outputs 24 V DC, 1 heating current input, I/O extensible up to 30 channels
	↑	
		X: 0... Profibus, Modbus, Ethernet Mod/TCP, Ethernet IP 1... DeviceNet 2... CANopen
Digital Inputs		
VARIO DI 2/24	KSVC-102-00121	Vario digital input module, input terminal block, spring-clamp connection, labeling field, 2 inputs, 24 V DC, 4-wire connection
VARIO DI 4/24	KSVC-102-00131	Vario digital input module, input terminal block, spring-clamp connection, labeling field, 4 inputs, 24 V DC, 3-wire connection
VARIO DI 8/24	KSVC-102-00141	Vario digital input module, input terminal block, spring-clamp connection, labeling field, 8 inputs, 24 V DC, 4-wire connection
Digital Outputs		
VARIO DO 2/24	KSVC-102-00221	Vario digital output module, output terminal block, spring-clamp connection, labeling field, 2 outputs, 24 V DC, 500 mA, 4-wire connection
VARIO DO 4/24	KSVC-102-00231	Vario digital output module, output terminal block, spring-clamp connection, labeling field, 4 outputs, 24 V DC, 500 mA, 3-wire connection
VARIO DO 8/24	KSVC-102-00241	Vario digital output module, output terminal block, spring-clamp connection, labeling field, 8 outputs, 24 V DC, 500 mA, 4-wire connection
VARIO DO 16/24	KSVC-102-00251	Vario digital output module, output terminal block, spring-clamp connection, labeling field, 16 outputs, 24 V DC, 500 mA, 3-wire connection
Relay Outputs		
VARIO DO 1/230	KSVC-102-01211	Vario digital output module, output terminal block, spring-clamp connection, labeling field, 1 relay changeover contact (hard gold plated), 5 - 253 V AC, 3 A
VARIO DO 4/230	KSVC-102-01231	Vario digital output module, output terminal block, spring-clamp connection, labeling field, 4 relay changeover contacts (hard gold plated), 5 - 253 V AC, 3 A
Analog Inputs		
VARIO AI 2/SF	KSVC-103-00121	Vario analog input module, input terminal block, spring-clamp connection, labeling field, 2 inputs, 0-20 mA, 4-20 mA, ±20 mA, 0-10 V, ±10 V, 2-wire connection
VARIO AI 8/SF	KSVC-103-00141	Vario analog input module, input terminal block, spring-clamp connection, labeling field, 8 inputs, 0-20 mA, 4-20 mA, ±20 mA, 0-10 V, ±10 V, (additional 0-40 mA, ±40 mA, 0-5 V, ±5 V, 0-25 V, ±25 V, 0-50 V), 2-wire connection
VARIO RTD 2	KSVC-103-00321	Vario analog input module, input terminal block, spring-clamp connection, labeling field, 2 inputs, RTD (resistance element), 2-, 3-, 4-wire connection
VARIO UTH 2	KSVC-103-00421	Vario analog input module, input terminal block, spring-clamp connection, labeling field, 2 inputs, TC (thermocouples), 2-wire connection
Analog Outputs		
VARIO AO 1/SF	KSVC-103-00211	Vario analog output module, output terminal block, spring-clamp connection, labeling field, 1 output 0-20 mA, 4-20 mA, 0-10 V, 2-wire connection
VARIO AO 2/U/BP	KSVC-103-00221	Vario analog output module, output terminal block, spring-clamp connection, labeling field, 2 outputs 0-10 V, ±10 V, 2-wire connection

Notation	Order-no.	Function
Analog/digital I/O-Modules		
VARIO UTH 4-DO8	KSVC-103-00431	Vario I/O-module, spring-clamp connection, labeling field, 4 inputs, TC (thermocouples), 2 wire connection + screening, 8 outputs 24 V DC, 1 heating current input
VARIO RTD 6-DO6	KSVC-103-00341	Vario I/O-module, spring-clamp connection, labeling field, 6 inputs, RTD (resistance element), 3 wire connection + screening, 6 outputs 24 V DC, 1 heating current input
VARIO UTH 8-DO8	KSVC-103-00441	Vario I/O-module, spring-clamp connection, labeling field, 8 inputs, TC (thermocouples), 2 wire connection + screening, 8 outputs 24 V DC, 1 heating current input
Power supply module for sensors		
VARIO CO 2/U	KSVC-103-02221	Vario analog output module, output terminal block, spring-clamp connection, labeling field, 2 outputs, 10V constant, 2 x 30mA (or 1 x 60mA)
Common Feed Terminal Blocks		
VARIO PWR IN/24	KSVC-105-00001	Vario bus terminal module, common feed terminal block, spring-clamp connection, labeling field, 24V DC, without fuse
Operating Panels for KS vario		
KSvarioBT	KSVC-111-00151	Full graphic Touch-Operating Panel with control software for KS vario with MODBUS Interface
KSvarioBT/WEB	on request	Full graphic Touch-Operating Panel with control software for KS vario with MODBUS Interface. WEB-Server for remote operation via browser
OPC/KSvarioBT	on request	OPC-Server for data-exchange between PC and KSvarioBT
Modbuscable RS485	KSVC-119-00001	RS485 cable between KsvarioBT and Modbuscoupler KS VARIO BK MOD, lenght: 5 meters
Modbuscable RS232	KSVC-119-00011	Field proofed RS232 cable between KsvarioBT and KS vario Controllers (engineering port), lenght: 3 meters

